

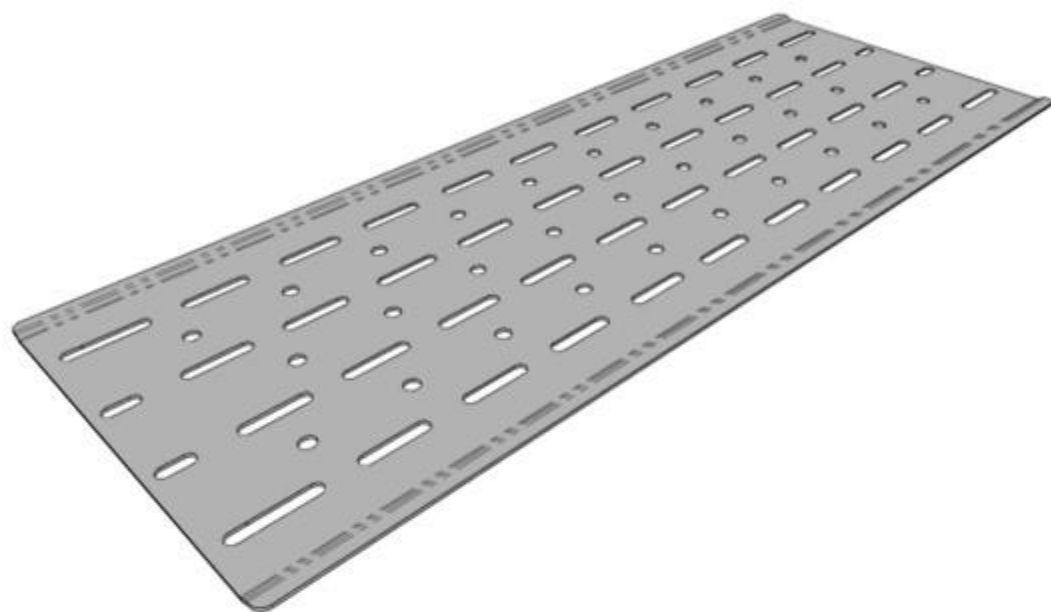

# ApexOEM

## 3218-109 ACCESSORY PLATE



INSTALL TIME: 30 min

### TOOLS REQUIRED

A	7/16" WRENCH
B	5/32" ALLEN KEY

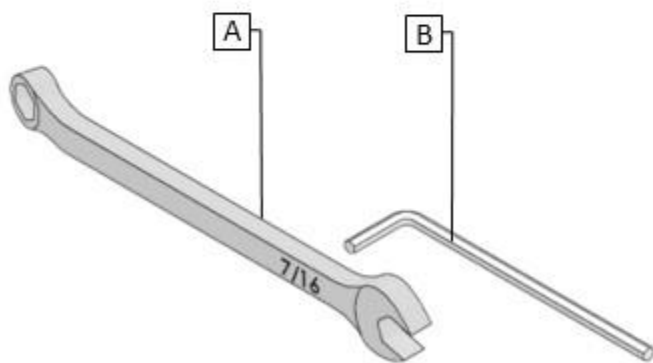



# ApexOEM

## 3218-109 ACCESSORY PLATE

### PARTS LIST

ITEM	QTY.	DESCRIPTION	PART NO.
1	1	ACCESSORY PLATE	A100-101
2	2	L-BRACKET	A100-109
3	4	CHANNEL NUT	191425-01
4	4	¼"-20 X 1" BUTTON HEAD SCREW	
5	2	¼"-20 X 3/4" HEX HEAD SCREW	
6	2	¼" NYLON INSERT LOCK NUT	
7	6	¼" FLAT WASHER	

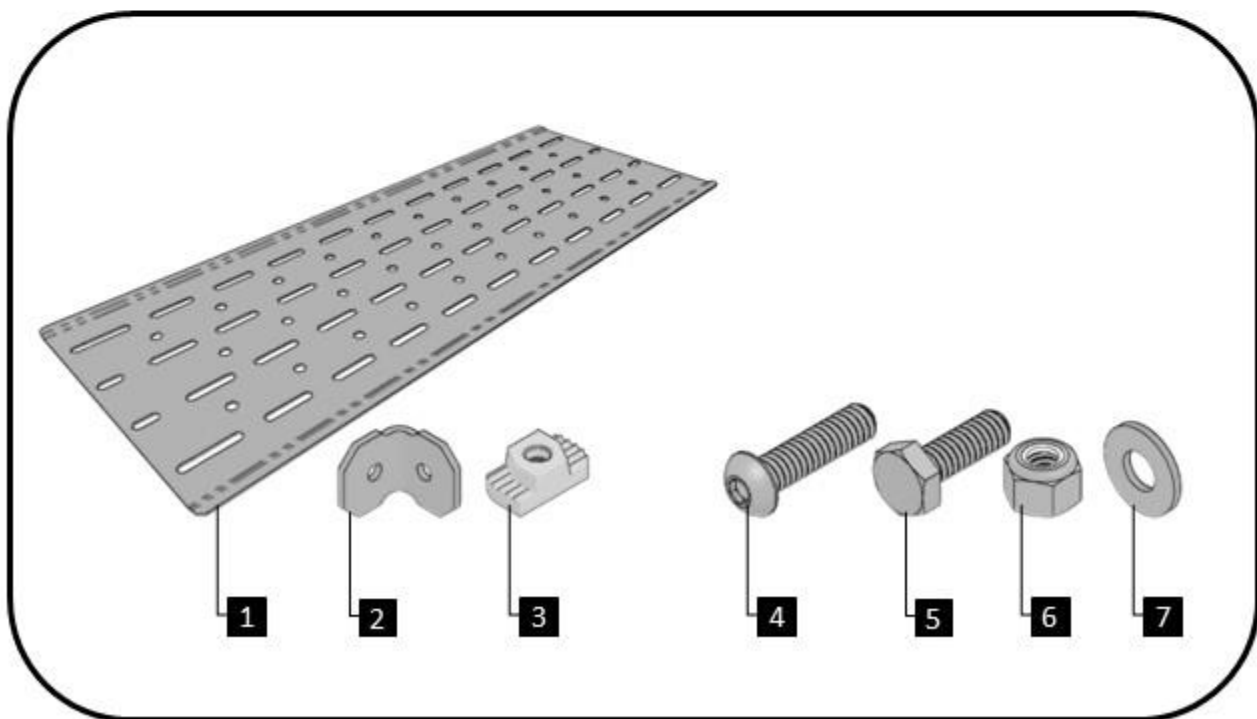

1

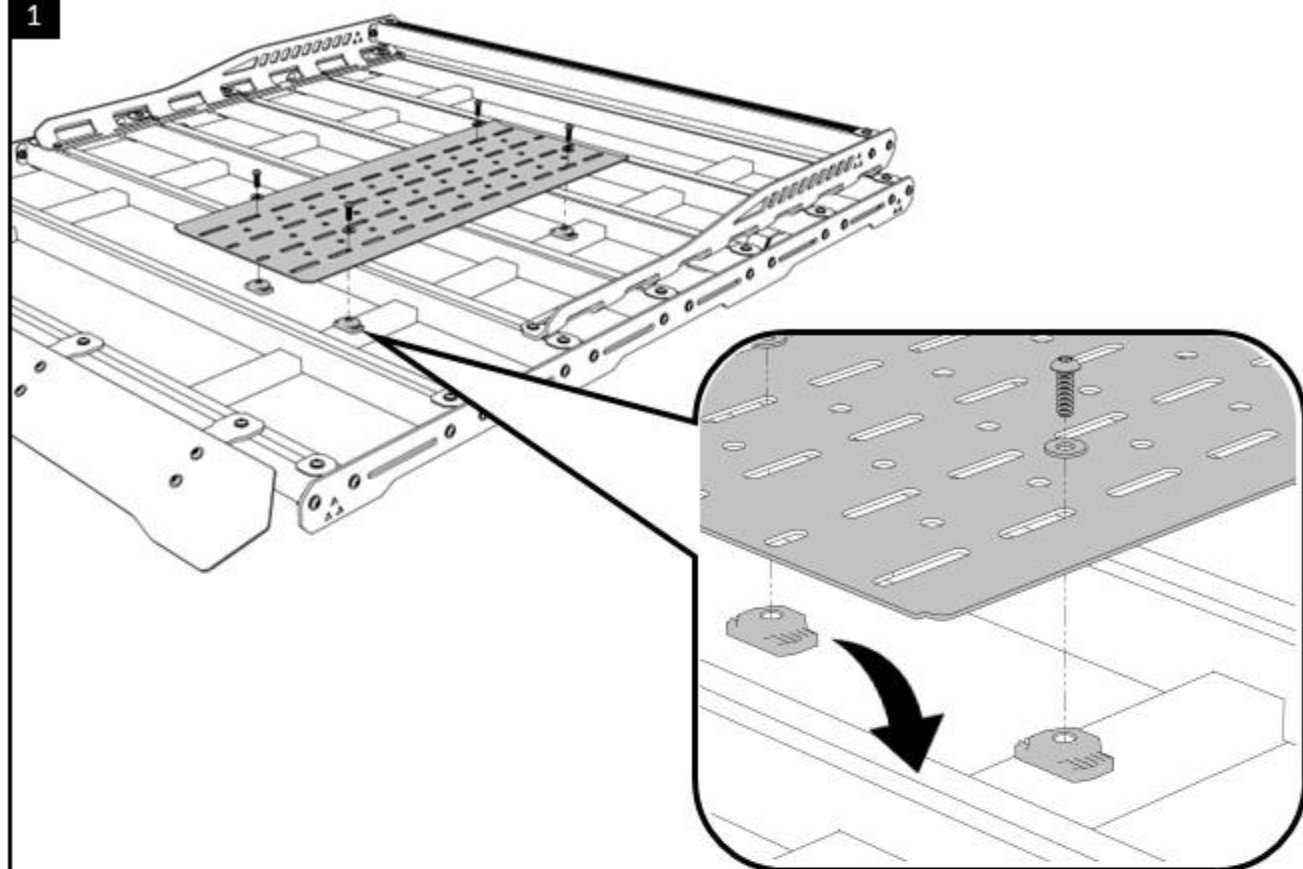

2

